

CODIGO	SECCION DEL CONDUCTOR [MM ²]	OBSERVACIONES
11056xx401 (56.401)	0.35 / 1.00	

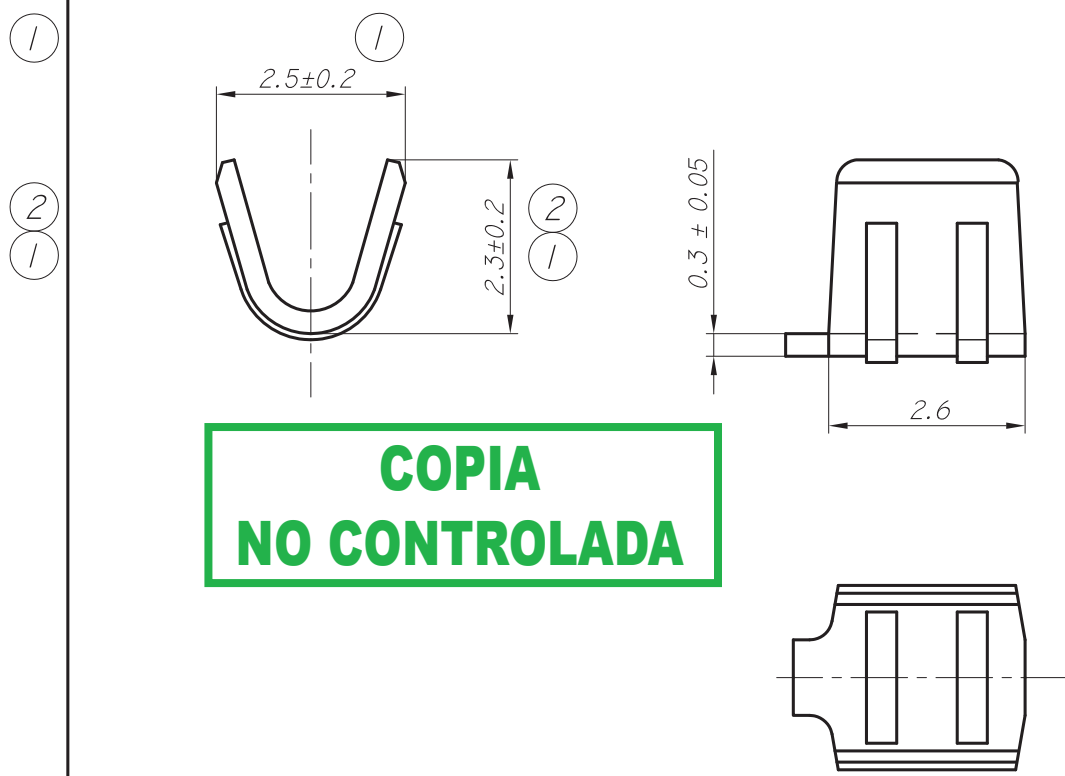

**COPIA
NO CONTROLADA**

**ESTE PLANO ESTA SUJETO A
MODIFICACIONES SIN PREVIO AVISO**

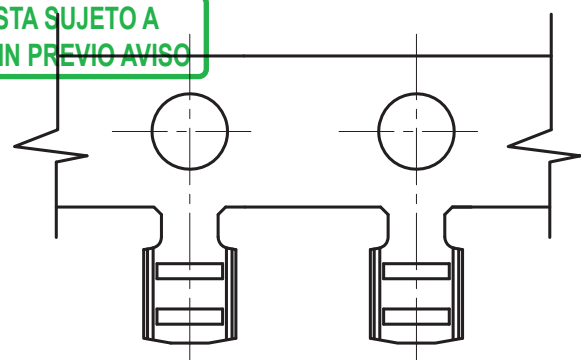

SENTIDO DE LA BANDA

ESC.: 5:1

26.12.12	3	SE AGREGA HOJA 3	G.G.		
25.07.12	2	2.3 ± 0.2 ERA 2.5 ± 0.2	G.G.	P.S.	O.A.C.
20.07.05	1	TOLERANCIAS ERAN ±0.15.	L.L.	P.S.	O.A.C.
FECHA	Nº	MODIFICACIONES	DIBUJO	REVISO	APROBO



INDUSTRIAS ZETA S.R.L.

TOLERANCIA NO ACOTADA:
LINEAL: ±0.15
ANGULAR: ± 1° 30'

MATERIAL: LATON	ESC.: 10:1 Y 5:1	DIBUJO	REVISO	APROBO
CODIGO MAS: /E = TERMINACION ESTAÑADA /N = TERMINACION NIQUELADA /P = TERMINACION PLATEADA /S = PIEZA SUELTA	HOJA: 2 DE 3	L.M.	O.A.C.	GARCIA
		14.07.04	14.07.04	14.07.04

DENOMINACION: CLIP DE UNION

PLANO PARA
CLIENTE N°:

56000